

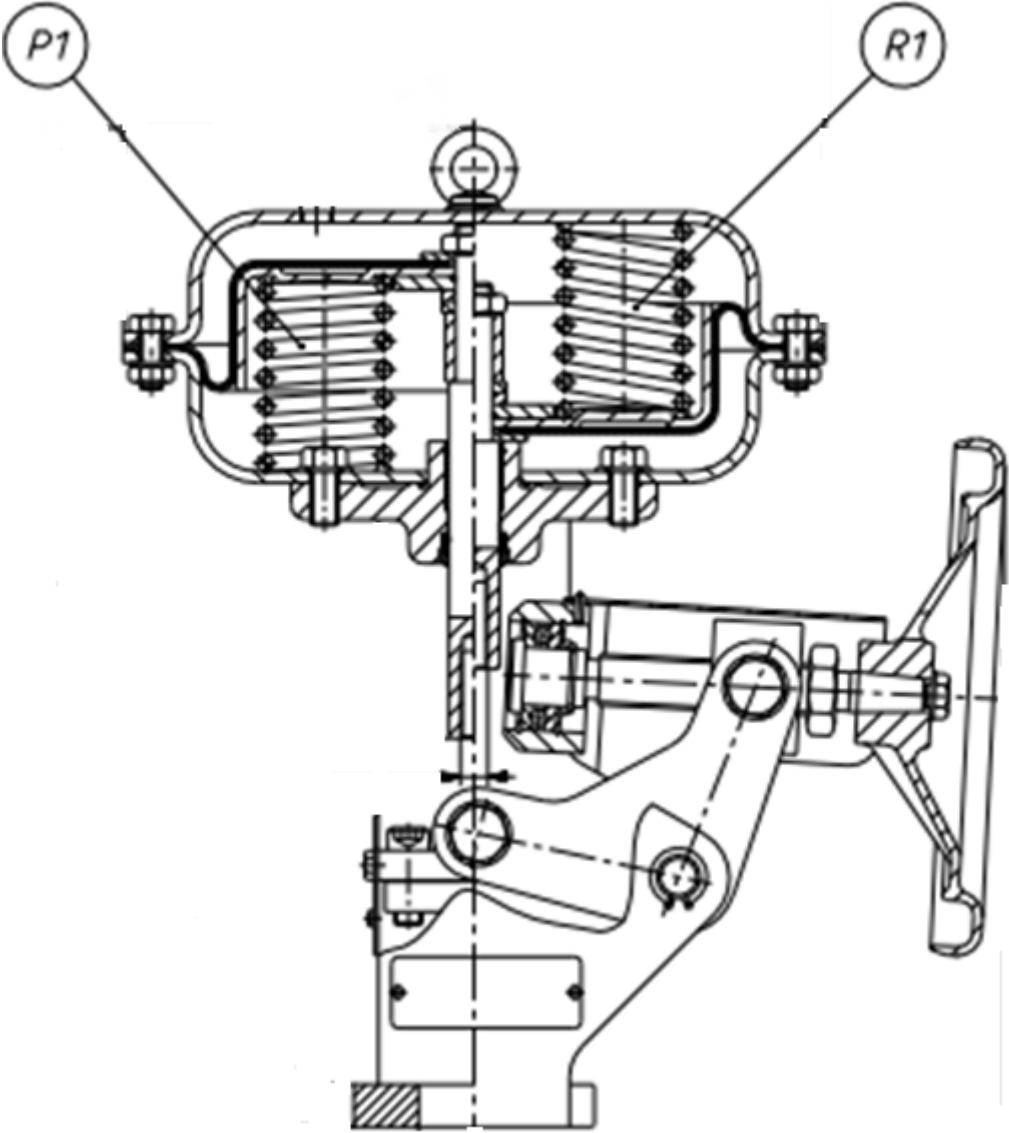

P1/R1 Instruction Manual



Contents:	Page
Introduction	2
1.0 Functional principle	3
2.0 Operating conditions	4
3.0 Changing the operating mode of the drive	4
3.1 Changing the control air range for P1/R1 pneumatic actuator	5
4. Diagrams / Spare parts lists	6
5. Contacting us	8



To ensure trouble-free and safe operation of the drive, it is essential to be familiar with the contents of this P1/R1 Instruction Manual, and also with the general instructions for installation and operation, before installing and operating the drive.

Failure to observe or comply with these operating instructions will invalidate the manufacturer's guarantee and liability. The manufacturer's general conditions of sales and terms of delivery shall apply unless otherwise stated.

1. Pneumatic Type P1/R1 drive

When the pressure rises in the actuator pressure chamber, a force is applied to the diaphragm in the actuator unit. If this force exceeds the spring force of the springs in the second chamber, the springs are compressed and the drive stem starts to travel out or in, according to the function. If the pressure continues to increase, once the maximum spring force is reached the springs will be pressed against the end-stop and the drive will halt. Thus, single acting pneumatic actuator can reach a defined position in proportion to the air pressure.

The size of the drive is based on the cm² surface of the diaphragm.

Drive size	Hub	Spring range (kPa)													
		1		2		3		4		5		6		7	
		20 – 100		40 – 200		40 – 120		80 – 240		60 – 140		120 – 280		180 – 380	
		How many springs	total compression (mm)	How many springs	total compression (mm)	How many springs	total compression (mm)	How many springs	total compression (mm)	How many springs	total compression (mm)	How many springs	total compression (mm)	How many springs	total compression (mm)
400	20	3	-	6	-	3	5	6	5	3	5+5	6	5+5	-	-
	20	3	-	6	-	3	5	6	5	3	5+5	6	5+5	12	5+5
630	38	3	-	6	-	3	9,5	6	9,5	3	9,5+9,5	6	9,5+9,5	12	9,5+9,5
	38	3	-	6	-	3	9,5	6	9,5	3	9,5+9,5	6	9,5+9,5	12	9,5+9,5
1000	50	3	-	6	-	3	12,5	6	12,5	3	12,5+12,5	6	12,5+12,5	12	12,5+12,5
	63	3	-	6	-	3	15,5	6	15,5	3	15,5+15,5	6	15,5+15,5	12	15,5+15,5
	38	3	-	6	-	3	9,5	6	9,5	3	9,5+9,5	6	9,5+9,5	12	9,5+9,5
1500	50	3	-	6	-	3	12,5	6	12,5	3	12,5+12,5	6	12,5+12,5	12	12,5+12,5
	63	3	-	6	-	3	15,5	6	15,5	3	15,5+15,5	6	15,5+15,5	12	15,5+15,5
	80	3	-	6	-	3	9,5	6	9,5	3	9,5+9,5	6	9,5+9,5	12	9,5+9,5
	38	3	-	6	-	3	9,5	6	9,5	3	9,5+9,5	6	9,5+9,5	12	9,5+9,5

Spring range and actuator sizes for pneumatic actuators of type P1/R1

P1 type drive: Single diaphragm actuator.

Safe position NO (open on loss of pressure)

When pressure rises in the upper chamber, the drive stem travels out.

R1 type drive: Single diaphragm actuator.

Safe position NC (closed on loss of pressure)

When pressure rises in the lower chamber, the drive stem travels in.

2. Operating Conditions

- Ambient temperature from - 25 to + 80°C, with silicone diaphragm of -40 °C to +80 °C
- Relative humidity up to 98 %,
- Permissible variations in air pressure + / -10%
- The control and tool air must be carried out according to DIN ISO 8573-1 Class 3.

The control and feed air supplies must contain no mechanical impurities, oil or corrosive substances, copper or aluminium alloys, and must be dehumidified such that the dew-point corresponds to a temperature that is at least 10 °C lower than the operating temperature of the position controller and the positioning drive.

3.0 Changing the operating mode of the actuator

1. No additional components are required in order to alter the direction of operation of type P1/R1 pneumatic actuator.
2. Disconnect the valve stem from the actuator stem.
3. Remove the top cover of the actuator (44), taking care that the tension lock is loosened right to the end in accordance with the note on the warning label.

The further steps in the procedure depend on the current operating mode of the drive before it is changed.

To change the drive function from P1 to R1, proceed as follows:

4. Loosen the thin nut (53) on the actuator stem.
5. Remove the diaphragm (55) with its diaphragm plate (45), spacer ring (47), washer (50) and cover (or spacer covers for drive sizes 630 and 1000) (48/49); take care, the stem must be secured before it can fall out of the sealing gland system.
6. Remove the springs from the lower casing.
7. Turn the diaphragm together with all the parts as listed above through 180 degrees, and fit them over the actuator stem in reverse order to that in which they were taken off.
8. Screw the thin nut onto the actuator stem so as to press all the above components together.
9. Place the springs in the cut-outs provided for the purpose on the diaphragm plate, so that they are evenly distributed around the axis of the stem.
10. Place the top cover of the actuator on the springs and compress the springs evenly. First tighten the tensioning nuts (remembering to insert the warning notice), until the upper drive cover is screwed firmly against the lower actuator cover. Then insert the rest of the bolts and screw on the respective nuts.

To change the drive function from R1 to P1, proceed as follows:

11. Remove the springs from the diaphragm plate.
12. Loosen the thin nut (53) on the drive stem.
13. Remove the diaphragm (55) with its diaphragm plate (45), spacer ring (47), washer (50) and cover (or spacer covers for drive sizes 630 and 1000) (48/49); take care, the stem must be secured before it can fall out of the sealing gland system.
14. Place the springs (54) in the places provided in the lower cover of the actuator (43).
15. Turn the diaphragm together with all the parts as listed above through 180 degrees, and fit them on the actuator stem so that the 6 mm diameter opening on the base and the nut on the edge of the diaphragm plate (45) lie in the axis of one of the openings on the circumference of the diaphragm.
16. Arrange the diaphragm system on the springs so that the springs are located in the corresponding cut-outs in the diaphragm plate. To check that the springs are in the correct position, gently rotate the diaphragm (to the position of the notch on the nut at the edge of the diaphragm plate) until the 6 mm opening on the base (45) is visible. By sighting through the opening, check that there is a spring in place on the underside.
17. Screw the thin nut (53) on to the actuator stem so that all the above components are pressed together.
18. Place the upper cover of the valve on the front of the stem and compress the springs evenly. First tighten the tensioning nuts (long nuts) (remember to insert the warning notice!), until the upper actuator cover is firmly screwed against the lower drive cover. Then insert the rest of the bolts and screw on the respective nuts.

3.1 Changing the control air range (spring range) for pneumatic actuator type P1/R1

The construction of the positioning drive permits the use of different control air ranges; this is achieved by applying different numbers of springs, or altering their pre-tensioning by fitting spacers:

- 5.0 mm – 2 off (for 20 mm hub),
- 9.5 mm – 2 off (for 38 and 80 mm hubs),
- 12.5 mm – 2 off (for 50 mm hub),
- 15.5 mm – 2 off (for 63 mm hub) – for drive sizes 1000 and 1500.

For the nominal range, the elements are mounted on the actuator stem on the inside of the diaphragm plate. Additional tensioning of the springs is achieved by fitting either one or two spacers to the outer side of the diaphragm plate, depending on the desired range.

The change in pre-tensioning is achieved by altering the position using the following spacers: 5 mm for the 20 mm hub; 9.5 mm for the 38 and 80 mm hubs; 12.5 mm for the 50 mm hub, and 15.5 mm for the 63 mm hub. Additional 4.5 mm thick spring plates are used for the 80 mm hub.

The number of components is given in Table 1, and the way in which they are fitted is shown in the overall layout drawing for positioning drives.

4. DRAWINGS / SPARE PARTS LIST

Number and description of parts.

No.	Description
Individual valve components	
1	Body
2a	Standard bonnel
2b	Extension bonnel
2c	Upper bonnel
3	Stem
4a	Parabolic valve plug
4b	Perforated plug
5	Valve seat
6	Clamping cage
7	Perforated clamping cage
8	Valve seat gasket
9	Body gasket
10	Guide sleeve
11	Blind plugs
12	Securing nut
13	Pressure sleeve
14	Thrust lever
15	Double-nut bolt
16	Nut
17	Thin nut
18	Double-nut bolt
19	Nut
20	Slot dowel
21	Company nameplate
22	Rivet pin
23	Bellows bonnel
24	Stuffing box
25	Bellows
26	Seal
27	Nut
28	Securing washer
29	Seal
30	Double-nut bolt
31	Nut
32	Guiding ring
33	Seal
34	Spacer sleeve (TA air)
35	Seal packing (TA air)
36	Spacer sleeve (TA air)
37	Stuffing box (TA air)

No.	Description
Individual components of positioning drive	
38	Pressure sleeve (TA air)
39	Leaf spring (TA air)
40	Pressure plate (TA air)
41	Double-nut bolt (TA air)
42	Bracket
43	Lower actuator cover
44	Upper actuator cover
45	Diaphragm plate
46	Stem
47	Spacer ring
48	Spacer sleeve
49	Spacer sleeve
50	Washer
51	Support ring
52	Tensioning nut
53	Thin nut
54	Spring
55	Diaphragm
56	Flange of actuator stem P1/R1-400
57	Stroke plate
58	Actuator supplier nameplate
59	Valve supplier nameplate
60	Warning label
61	Stroke indicator
62	Sliding sleeve
63	Cover
64	Air vent plug
65	Rivet pin 3x6
66	Bolt
67	Bolt
68	Bolt
69	Bolt
70	Shaft bolt
71	Nut
72	Washer
73	O ring
74	Washer ring
75	Circlip
76	O ring

No.	Description
77	Z wiper ring
78	O ring
79	Nut
80a	Shaft connecting piece, upper, P1/R1 630
80b	Shaft connecting piece, upper, P1/R1 1000; 1500
81a	Shaft connecting piece, lower, P1/R1 630
81b	Shaft connecting piece, upper, P1/R1 1000; 1500
82a	Connecting sleeve P1/R1-630
82b	Connecting sleeve P1/R1 1000; 1500
83	Grub screw
84	Drive bolt
85	Drive wheel
86	Support nut
87	Lever
88	Drive joint
89	Lever axle
90	Pivot pins
91	Spindle nut
92	Drive cover
93	Longitudinal journal bearing
94	Slot dowel
95	Support ring (P1/R1B-400;630)
96	Circlip
97	Circlip
98	Circlip
99	Bolt
100	Washer
101	Connecting piece (for electrical positioning motors)
Individual components of type 20 drive	
102	Drive bracket
103	Drive wheel
104	Drive sleeve
105	Drive cover
106	Drive shaft
107	Slot
108	Stroke plate
109	Ball bearing
110	Oiler
111	Indicator
112	Slot dowel
113	Shaft bolt

Figure 1) pneumatic drive type P1/R1 and side-mounted hand-wheel (cross-section)

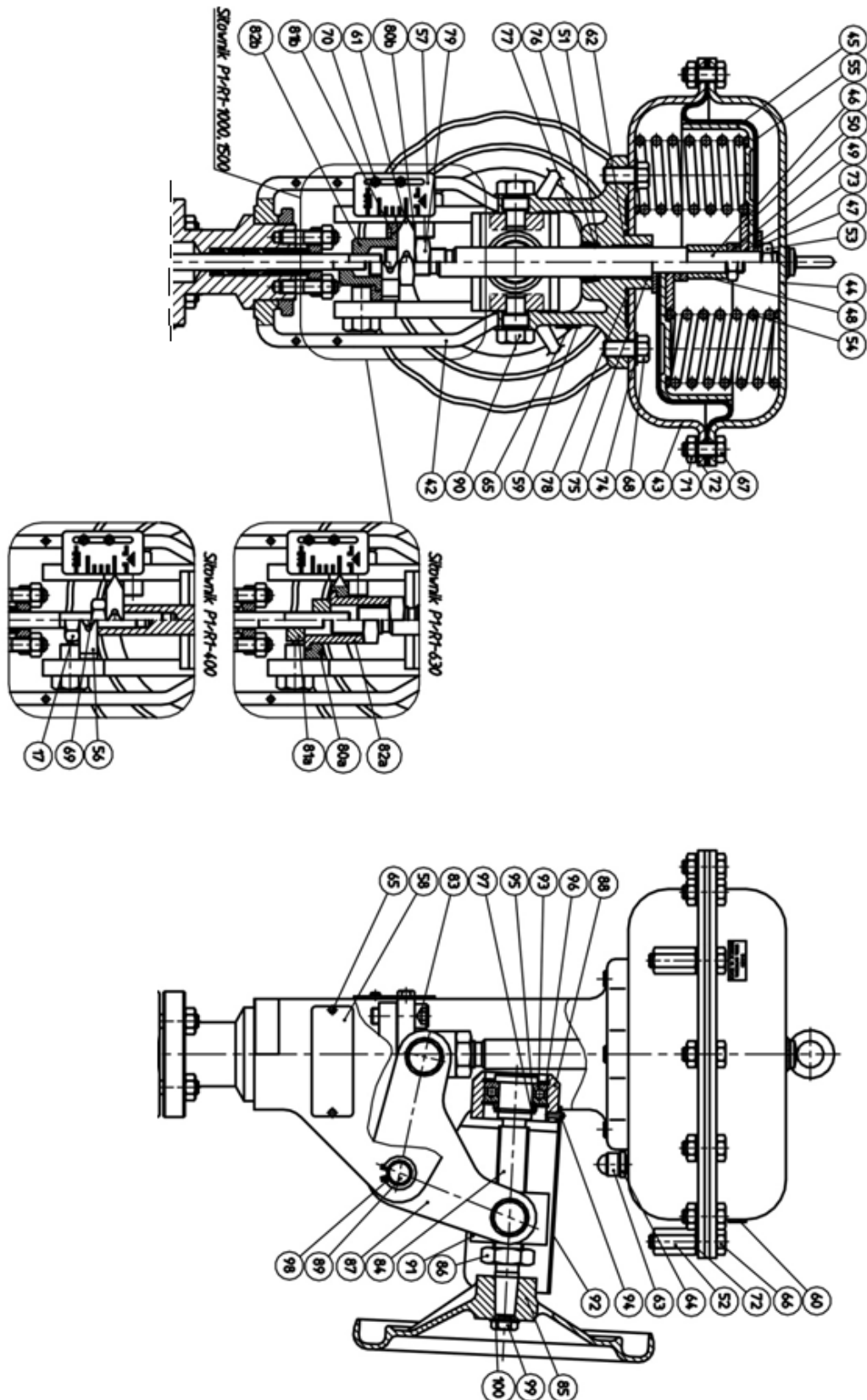

5. Contacting us

Details / specific information (Operating instructions with spare parts lists) are available for download on our website.

PRE-VENT GmbH

Sales - Production - Servicing

Gewerbepark Lindach A9
84489 Burghausen, Germany

fon +49 8677 98788-0

fax +49 8677 98788-80

Email: office.pre-vent@fiwagroup.com

Web: www.pre-vent.com

Manual version 1.1 31.08.2012