

# control valve type BR 12b



**strong**  
**arguments**  
of modern technology

# Globe-cage control valve

## Application

They are used as an executing element in instrumentation and remote control systems to control the liquids, vapours and gas flow.

The wide range of material versions, advantageous operating pressures and temperatures, numerous design variations matched to the process requirements are a reason, the valves shall be used at the most heavy-duty conditions in power and heat engineering, petrochemical and chemical industry, metallurgy, etc.

## type BR 12b

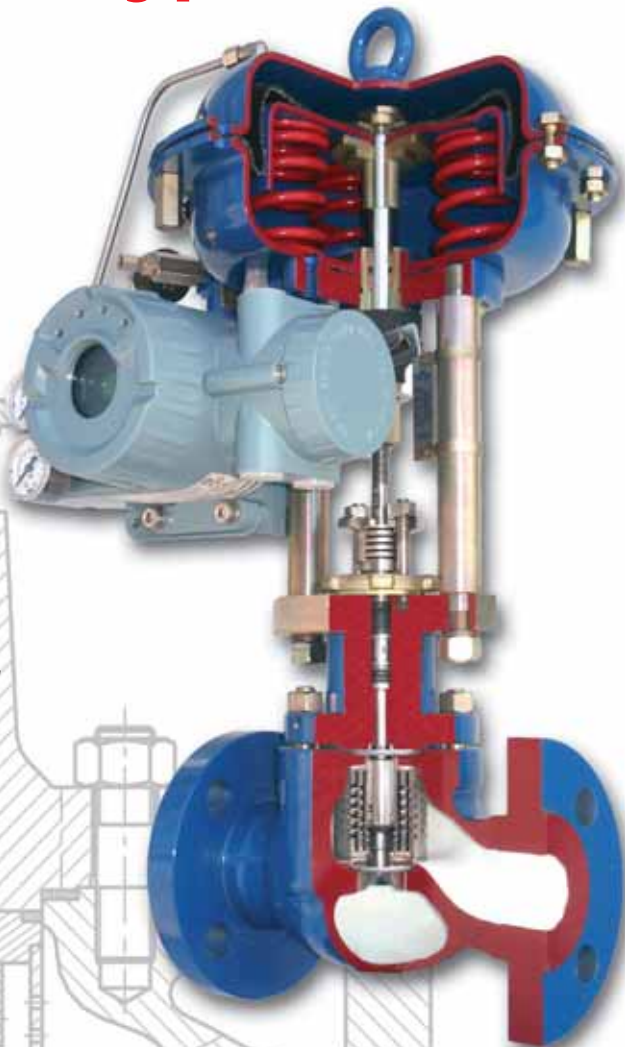

## Characteristics

- Various material versions of the valve cast and internal parts, matched to the specific operating conditions
- Designs reducing the generated noise level, increasing the cavitations and flashing resistance, enabling throttling to be eliminated
- A wide range of pressure ratings from PN 10 to PN 420, as well as of the flow ratios and of the control
- Reduced emission of aggressive and toxic fluids into the environment due to the bellows seal or compression gland corresponding to TA-LUFT regulations
- Easy disassembly and installation of the valve internal components for the purpose of inspection and service
- Long life and operating reliability due to high quality materials being used and to the surface improvement techniques (burnishing, stellite, heat treatment, CrN coatings)
- An ability to cooperate with multi-spring actuators P1/R1 (cast yoke) and P/R (column) to totally reversible operation, as well as a possibility to vary the spring range - with no extra parts (the number of springs unchanged)
- A possibility to fit the actuators with a lateral (P1/R1) or a top (P/R) manual drive
- Diagnostic possibilities for the „valve-actuator“ system due to the intelligent electropneumatic positioners being used
- A wide range of electric drives
- Special versions available
  - For oxygen
  - For liquid and gas fuels
  - For low temperature fluids (liquid oxygen, nitrogen)
  - For acid H<sub>2</sub>S-containing gases
  - With a heating jacket
  - Service at flammable conditions acc. to Directive 94/9/EG ATEX
- The product designing and manufacture are in compliance with the specifications of the quality management system ISO 9001, of the directive 97/23/EG and of AD 2000 Merkblatt regulations

# Construction and technical specification

**Body (1)** Single seat, cast

**Nominal dimensions** DN 25; 40; 50; 80; 100; 150; 200; 250

**Pressure rating designation**

PN 10; 16; 25; 40 and PN 20; 50; 110; 150; 260; 420 to PN - ISO 7005-1: 1996

PN 63; 100; 160; 250; 320; 400 to PN - H - 74307: 1985; PN - H - 74306: 1985

**Divided as follows**

DN 25 ... 250; PN 10 ... 110

DN 25 ... 150; PN 150; 160

DN 25 ... 100; PN 250 ... 420

**Connections**

Flanged: to table 1;

Butt welding ends, BW type; to tables 12 and 13

Socket welding ends, SW type; to table 14

The design of steel flanges PN 20; 50; 110; 150; 260; 420 enables assembling them with flanges to American standards ANSI/ASME B16.5 and MSS SP 44. Under the American system, flanges are designated with rated values in „Classes“ to the said values pressure ratings (PN) as now been discribed.

The equipment pressure designations are as follows:

Class 150: PN 20      Class 300: PN 50      Class 600: PN 110

Class 900: PN 150      Class 1500: PN 260      Class 2500: PN 420

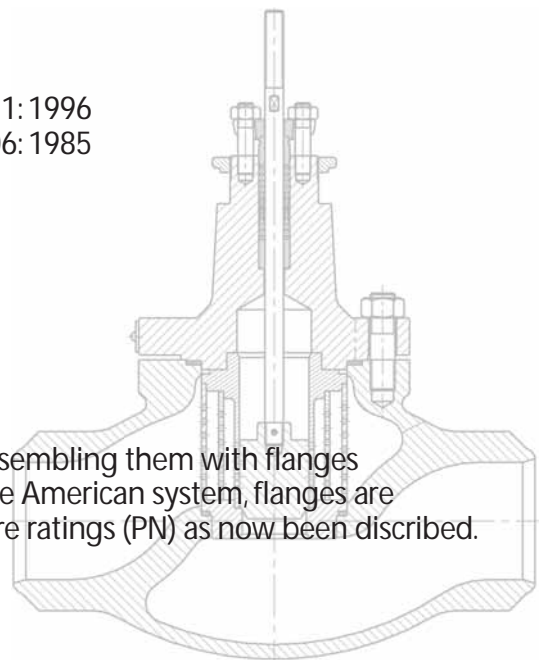

**Tab. 1: Flanged connections**

Pressure rating	Connection type			
	Face	Groove	Key	Groove to the ring
	Designation			
PN 10; 16; 25; 40; 63; 100; 160; 250; 320; 400	B	D	F	-
PN 20; 50	B1	D1	F1	J
PN 110; 150; 260; 420	B2	D1	F1	J
ANSI 150; 300; 600; 900; 1500; 2500	RF	GF	FF	RTJ

## Construction length

- flanged valves to PN-EN 60534-3-1; PN-M-74005; ISA S75.16-1993; fig. 5; tables 9; 10
- valves with welding terminals; fig. 5; table 11
- to PN\_EN 60534-3-3:
  - for PN10 ... 110 and PN20 ... 110
- like flanged valves PN 160:
  - for PN 160 and PN 150
- like flanged valves PN 400:
  - for PN 250 ... 400 and PN 260 ... 420

**Materials** to table 2

Operating pressure and temperature relation to the pressure rating and material to diagrams 1 and 2

**Bonnet (2)**

**Standard** Temperature range -46° C to +300° C

**Extension** Temperature range -198° C bis +650° C

**Bellows** Temperature range -100° C bis +400° C

**Plug (3)** Shaft guided, metal seat

Versions: contoured plug; perforated plug

Flow characteristics: equal percentage P, linear L

quick opening - S (only for profile plug)

**Rangeability** 50 : 1

**Seat (4)** Fitted and sealed to the body, hard

**Stem (5)** Burnished and polished on the sealing surface

**Control cage (6a)**

Multi-opening element performing the flow characteristic provided and locking the seat

## Throttling cages (6b, 6c)

Drilled sleeve to reduce the pressure drop on the control cell. According to the needs and to the design conditions, following options are available: valves with one or two cages; valves without a cage

## Gaskets of the body (7), of the seat (8) and of the control cell (9):

Spiral „graphite + 1.4571“ over the entire manufacturing range

## Stem sealing (10)

- sealing packing PTFE- V-held down by a helical spring (17)
- ring gaskets formed from woven packing cords (PTFE + GRAPHITE)
- graphite sets (expanded and silky graphite) or gaskets from woven graphite cords
- TA-Luft seal with PTFE-V sealing package or a graphite set, seal designs to figs. 1 and 2 use range to table 3

## Seat leakage

Standard: below 0.01% Kvs (Class IV to PN- IEC 60534-4)

Increased: 3·10<sup>-3</sup>D·Δp [cm<sup>3</sup>min] (Class V to PN-IEC 60534-4)

## Fluid flow direction

Under the plug (flow to open)

## Flow coefficients

Acc. to table 4

Fig. 1a

Valve BR 12b  
with unbalanced plug

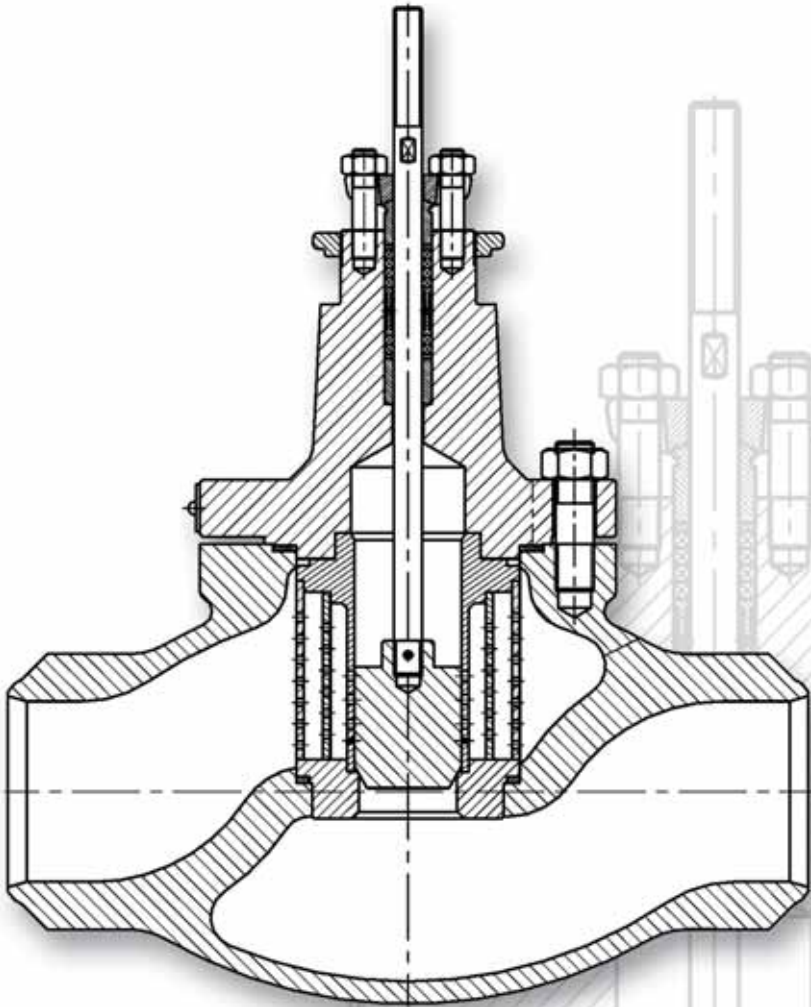
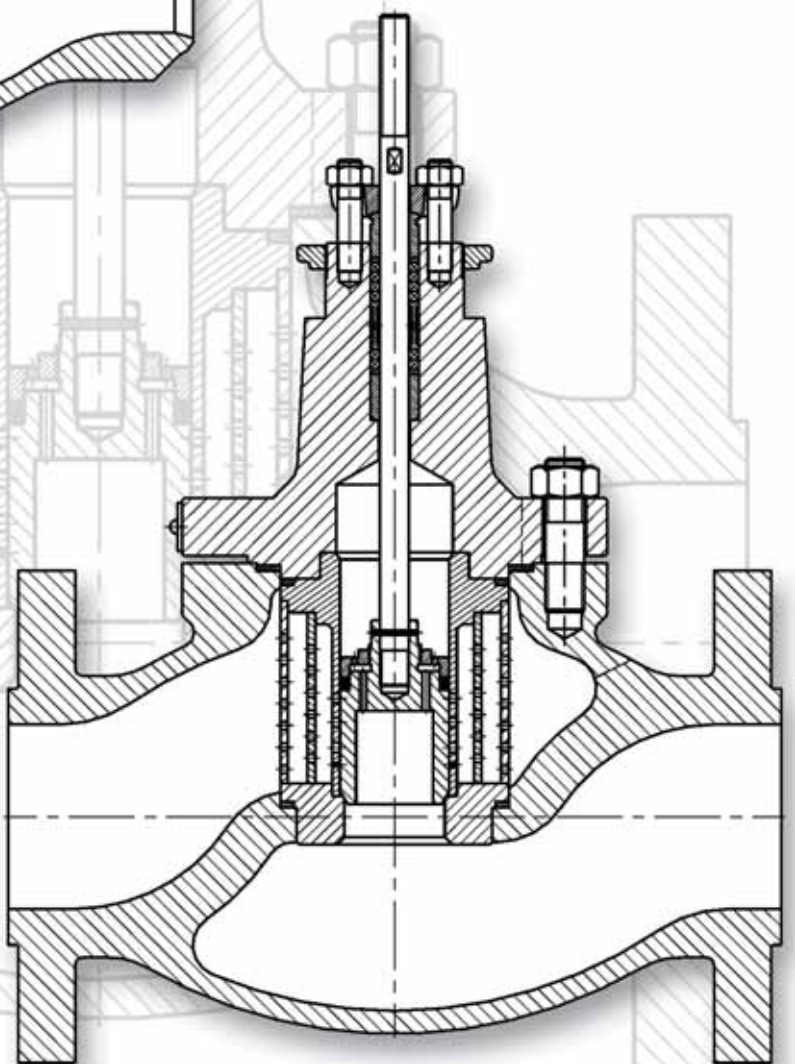
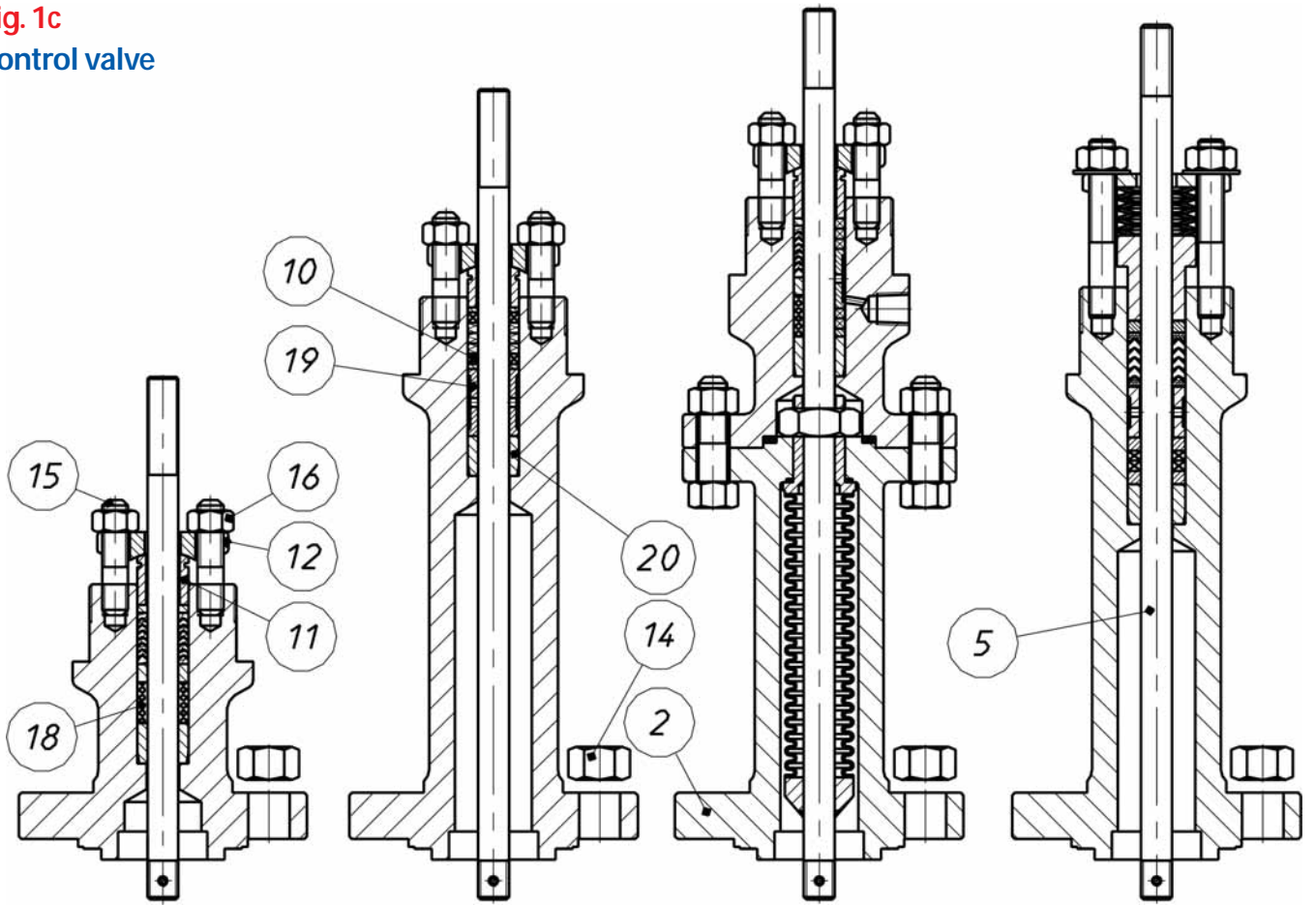

Fig. 1b

Valve BR 12b  
with balanced plug



**Fig. 1c**  
Control valve



Standard bonnet  
PTFE-V-packing

Extended bonnet  
PTFE + graphite-  
packing

Bellows bonnet  
PTFE + graphite-  
packing

Extended bonnet  
with TA-Luft packing

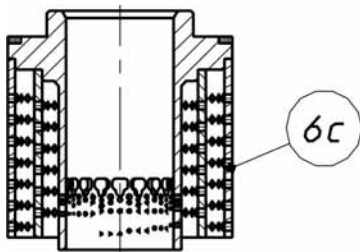

Control sleeve  
with throttling cages I and II

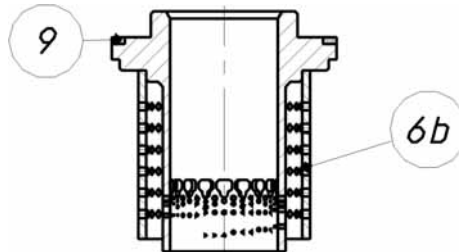

Control sleeve  
with throttling cage II

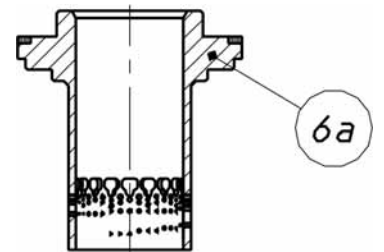

Control sleeve

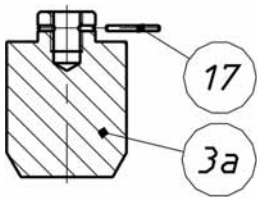

Unbalanced  
plug

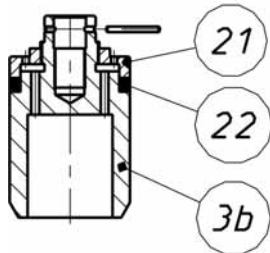

Balanced  
plug

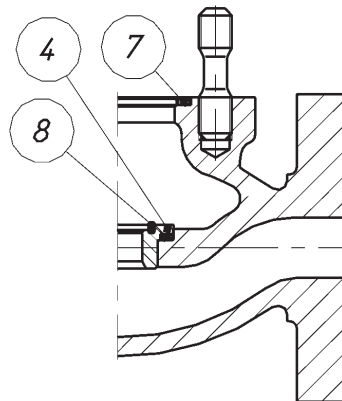

Flanged body

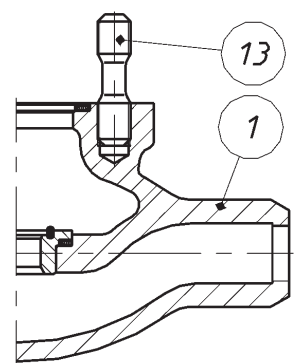

Body with welding ends  
(BW type)

## Tab. 2: List of parts and materials

No.	Part		Materials		
1	Body		GP 240 GH ; (1.0619) WCB	G17CrMo 9-10 ; (1.7379) WC9	GX5CrNiMo 19-11-2 ; (1.4408) CF8M
2	Seal	DN 25 ... 50	S 355 J2G3 (1.0570)		X6CrNiMoTi 17-12-2 ; (1.4571)
		DN 80 ... 250	GP 240 GH ; (1.0619) WCB	G17CrMo 9-10 ; (1.7379)	G17CrMo 9-10 ; (1.7379) WC9
3a, b	Perforated unbalanced plug		X6CrNiMoTi 17-12-2 ; (1.4571)		
	Perforated balanced plug		X6CrNiMoTi 17-12-2 ; (1.4571) + Stellite + CrN X17CrNi 16-2 ; (1.4057) + Heat-treating		
4	Seat		X6CrNiMoTi 17-12-2 ; (1.4571)		
			X6CrNiMoTi 17-12-2 ; (1.4571) + Stellite X17CrNi 16-2 ; (1.4057) + Heat-treating		
5	Stem		X6CrNiMoTi 17-12-2 ; (1.4571)		
			X6CrNiMoTi 17-12-2 ; (1.4571) + Stellite + CrN X17CrNi 16-2 ; (1.4057) + Heat-treating		
6a	Control sleeve		X6CrNiMoTi 17-12-2 ; (1.4571)		
6b	Throttling cage I		X17CrNi 16-2 ; (1.4057) + Heat-treating		
6c	Throttling cage II				
7	Body gasket		Graphite 98% + 1.4571 (spiral)		
8	Seat gasket				
9	Control cage gasket				
10	Sealing packing		PTFE + Graphite		
			PTFE „V“ (Rings)		
			Graphite		
11	Hold down sleeve		X6CrNiMoTi 17-12-2 ; (1.4571)		
12	Hold down lever		S 355 J2G3 ; (1.0570)		
13	Body bolt	PN 10 ... 50	8,8	A4 - 70	
		PN 63 ... 420	42CrMo4 (1.7225)	21CrMoV 5-7 (1.7709)	X6NiCrTiMoVB 25-15-2 (1.4980)
14	Body nut	PN 10 ... 50	8,8	A4 - 70	
		PN 63 ... 420	42CrMo4 (1.7225)	21CrMoV 5-7 (1.7709)	X6NiCrTiMoVB 25-15-2 (1.4980)
15	Bonnet bolt		8,8	A4 - 70	
16	Bonnet nut		8,8	A4 - 70	
17	Pin with notches		X6CrNiMoTi 17-12-2 ; (1.4571)		
18	Spring		12R10 (SANDVIK)		
19	Distance sleeve		X6CrNiMoTi 17-12-2 ; (1.4571)		
20	Guiding sleeve		X6CrNiMoTi 17-12-2 ; (1.4571)		
			X6CrNiMoTi 17-12-2 ; (1.4571) + Stellite + CrN X17CrNi 16-2 ; (1.4057) + Heat-treating		
21	Plug nut		X6CrNiMoTi 17-12-2 ; (1.4571)		
22	Plug sealing ring		Expanded graphite		

Material	Norm
GP 240 GH ; (1.0619)	EN 10213-2
WCB	ASTM A216
G17CrMo 9-10 ; (1.7379)	EN 10213-2
WC9	ASTM A217
GX5CrNiMo 19-11-2 ; (1.4408)	EN 10213-4
CF8M	ASTM A351
S 355 J2G3 ; (1.0570)	EN10025
13CrMo 4-4 ; (1.7335)	EN10028
X6CrNiMoTi 17-12-2 ; (1.4571)	EN10088
X17CrNi 16-2 ; (1.4057)	EN10088
C45 (1.0503)	EN10083-1
X30Cr13 (1.4028)	EN10088
8.8	EN 20898-1
A4 - 70	EN ISO 3506-2
42CrMo4 ; (1.7225)	EN 10269
21CrMoV5-7 ; (1.7709)	EN 10269
X6NiCrTiMoVB 25-15-2 ; (1.4980)	EN 10269

### Note

In order to harden the valves internal components following technology is used:

- Stellite - surface padding with stellite: ~ 40 HRC
- CrN coating - introducing chromium nitride down to ca 0.1 mm into the part external layer, ~ 950 HV
- Heat resistant construction: plug (~ 45 HRC), seat (~ 35 HRC), stem (~ 32 HRC), guide bushing (~ 32 HRC)

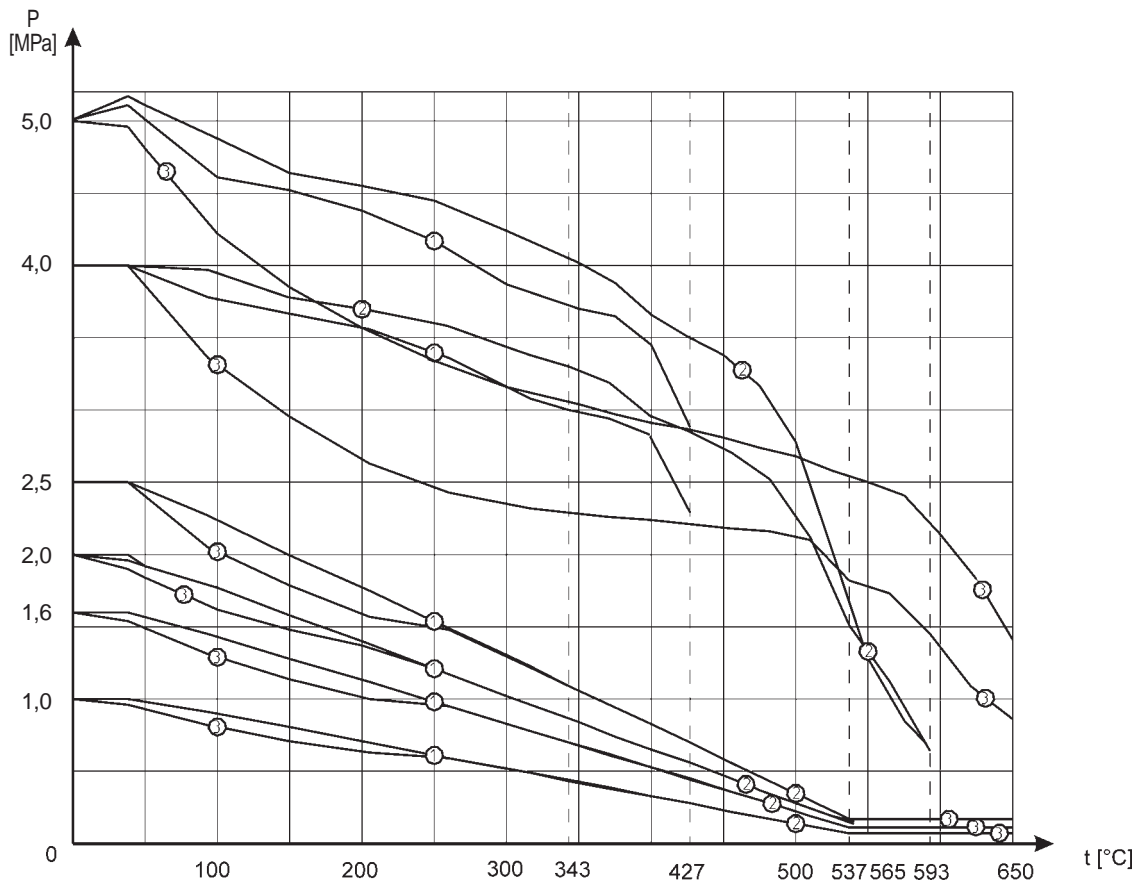
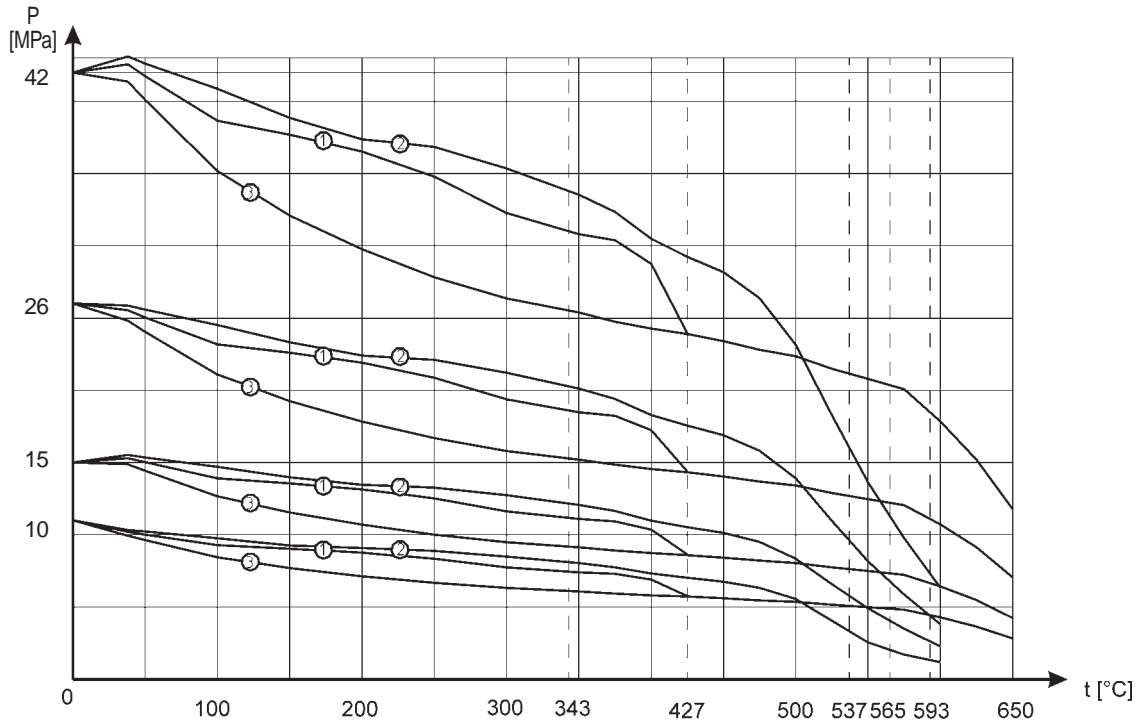

**Body-material, nominal pressure, operating pressure and temperatures**

Material	GP 240 GH (1.0619) / A216 WCB	G17CrMo 9-10 (1.7379) / A217 WC9	GX5CrNiMo 19-11-2 (1.4408) / A351 CF8M
Characteristic line (Diagr. 1 and 2)	1	2	3
Temperatur range (°C)	-29 ... +427	-29 ... +537 <sup>1)</sup> ; -29 ... +593 <sup>2)</sup>	-198 ... +537 <sup>1)</sup> ; -198 ... +650 <sup>2)</sup>

- 1) Temperature range for flanged valves
- 2) Temperature range for valves with welding ends

**Diagram 1 and 2 are based on ISO 7005-1:2002**

## Versions

12b valves are recommended for the most heavy duty applications, where hazards of excess noise, of cavitations, flashing or a choked flow are faced.

The valve design and material versions are selected according to the operating conditions. Selection of a design solution is based on the computer calculations of the flow coefficient, the noise level, the fluid state. The result of such activities depends on the accuracy of the information submitted by the client. Using a multi-opening control element enables the noise level to be reduced by ca 10 dBA as compared to the solutions with a profile plug.

Additional noise reduction (ca. 5 dBA) is achieved by implementing a reducing which causes lower pressure drop on the control cage. Such version is recommended in case of a choked-flow, cavitations and flashing as well.

Multi-opening designs give the higher pressure recovery coefficient FL, which enables a higher flow as compared to the conventional version, with Kvs and  $\Delta p$  values remaining unchanged.

An important advantage for a 12b valves purchaser is a chance to get the maximum flow coefficient for any nominal dimension and any control characteristics, as well as to reduce the drive cost due to unbalanced plug solution. For fluids, it is often advantageous to use reduction connections on the outlet (diffusers). When it is necessary (noise, throttled flow), the diffusers can be equipped with additional drilled structures, like plates to be fixed between the flanges or welded inside the reducer.

On the client's request, as well as when it is demanded by the flow conditions, special versions are proposed as far as materials, flow coefficients, control characteristics, seat leakage, etc. are concerned.

**Tab. 3: Packing and its use**

Packing type	PN	Temperature [ °C ]		
		Bonnet type		
		Standard	Extended	Bellows
PTFE-V-Ring	to 110)*	-46° C ... +200° C	-198° C ... +300° C	-100° C ... +200° C
PTFE + Graphite				
PTFE-V / TA-Luft				
Graphite	to 420)*	Up to +300° C	Up to +537° C , (+650° C)**	Up to +400° C
Graphite / TA-Luft				

)\* PN50 - for bellows bonnet

)\*\* for valves with welding ends

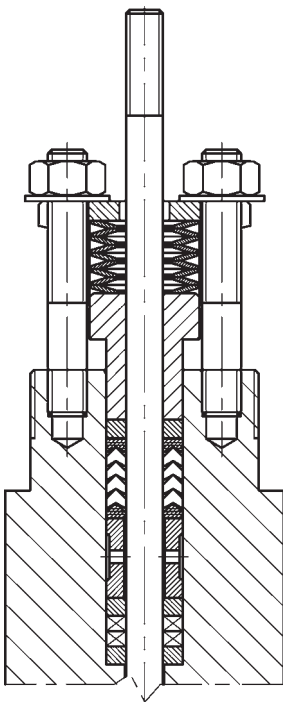

Stuffing box packing according to TA-Luft (PTFE -V-Ring)

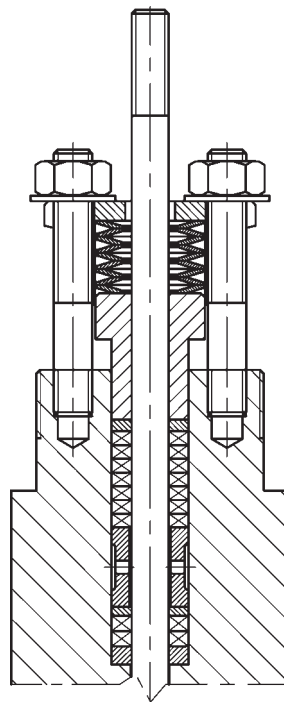

Stuffing box packing according to TA-Luft (Graphite)

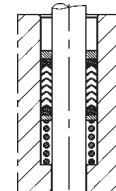

Stuffing box (PTFE-V-Ring)

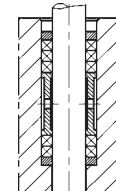

Stuffing box (PTFE + Graphite)

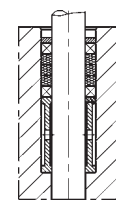

Stuffing box (Graphite)

**Tab. 4: Flow coefficients Kvs (m<sup>3</sup>/h) for contoured- and perforated plugs**

Kvs		Stroke [mm]	Diameter valve seat [mm]	A [cm <sup>2</sup> ]	F <sub>D</sub>		Nominal size valve (DN)							
L	P				KI. IV	KI. V	25	40	50	80	100	150	200	250
10		20	20,64	3,3	0,33	2,1	· K1 **)	K2	K2					
16			25,25	5,0	0,4	2,6		K2	K2					
25			31,72	7,9	0,5	3,3		· K1	K1	K2				
40		38	41,25	13,4	0,7	4,6			· K1	K2	K2			
63			50,8	20,3	0,8	5,2				K1	K2	K2		
94			66,7	34,9	1,1	7,2				· K0	K1	K2	K2	
125		50	88,9	62,1	1,4	9,1				K1	K2	K2	K2	
160							· K1	K2	K2	K2				
200		63	107,92	91,5	1,7	11,0					K1	K2	K2	
250											K1	K2	K2	
320		80	126,95	126,6	2,0	13,0					K1	K2	K2	
500		100	158,72	197,9	2,5	16,0							K1	K2
630			203,2	324,3	3,2	21,0								K1
800	-													K1
														K1

Calculation factors  
F<sub>L</sub> = 0,95; X<sub>T</sub> = 0,78; F<sub>D</sub> = 0,1; xF<sub>Z</sub> = 0,75

**Note**

- no version for PN 250 ... 420
- \*\* - for PN 10 ... 50 - K0
- „K“ - maximum number of throttle cages per valve  
K0 - no reducing cage  
K1 - one reducing cage  
K2 - two reducing cages



Seat and plug  
complete



Seat and plug  
separate

**Tab. 5: driving force [kN] of pneumatic actuators**

Actuator size	Direct action (type P ; P1)			Reverse action (type R ; R1)					
	Supply pressure [kPa]			Diaphragm pressure span [kPa]					
	1,4	2,5	4,0	0,2 - 1,0	0,4 - 1,2; 0,4 - 2,0	0,6 - 1,4	0,8 - 2,4	1,2 - 2,8	1,8 - 3,8
250	1,0	3,8	7,5	0,5	1,0	1,5	2,0	3,0	-
400	1,6	6,0	12,0	0,8	1,6	2,4	3,2	4,8	-
630	2,5	9,5	18,9	1,3	2,5	3,8	5,0	7,6	11,3
1000	4,0	15,0	30,0	2,0	4,0	6,0	8,0	12,0	18,0
1500	6,0	22,5	45,0	3,0	6,0	9,0	12,0	18,0	27,0
3000	12,0	45,0	90,0	6,0	12,0	18,0	24,0	36,0	54,0

**Note**

- For direct action actuators, the spring range of 20-100 kPa has been provided.
- For the interpretation of electrically and other actuators the values of table 4 and 5 can be used.

**Tab. 6: Pressure drops  $\Delta p$  [MPa] for valves with pneumatic actuators seat leakage class IV an V**

Diameter valve seat [mm]	Nominal size valve [DN]	Stroke [mm]	Actuator size	Increase control pressure „close valve“			Increase control pressure „open valve“		
				Sup. pressure [kPa]	$\Delta P$ [MPa]		Spring range [kPa]	$\Delta P$ [MPa]	
					Cl. IV	Cl. V		Cl. IV	Cl. V
20,64	25; 40; 50	20	250	140	2,0	-	20 - 100	0,5	-
				250	10,0	4,8	40 - 120	2,0	-
				400	21,0	15,9	60 - 140	3,4	-
			400	140	3,7	-	80 - 240	4,9	-
				250	16,6	11,5	120 - 280	7,8	2,6
				400	28,0	28,0	20 - 100	1,4	-
25,25	40; 50		250	140	1,2	-	40 - 120	1,2	-
				250	6,7	2,3	60 - 140	2,2	-
				400	14,2	9,8	80 - 240	3,2	-
			400	140	2,4	-	120 - 280	5,2	0,8
				250	11,2	6,8	20 - 100	0,8	-
				400	23,2	18,8	40 - 120	2,4	-
31,72	40; 50; 80	400	140	1,4	-	60 - 140	4,0	-	
			250	7,0	3,4	80 - 240	5,6	1,2	
			400	14,5	11,0	120 - 280	8,8	4,4	
		630	140	2,5	-	20 - 100	0,4	-	
			250	11,3	7,8	40 - 120	1,4	-	
			400	23,2	19,7	60 - 140	2,4	-	
41,25	50; 80; 100	630	140	1,3	-	80 - 240	3,4	-	
			250	6,3	3,5	120 - 280	5,4	1,9	
			400	13,0	10,2	180 - 380	13,7	10,1	
		630	140	0,9	-	20 - 100	0,4	-	
			250	4,3	2,1	40 - 120	1,3	-	
			400	9,0	6,9	60 - 140	2,2	-	
50,8	80; 100; 150	630	140	0,9	-	80 - 240	3,1	0,3	
			250	4,3	2,1	120 - 280	4,9	2,1	
			400	9,0	6,9	180 - 380	7,5	4,8	
		1000	140	1,6	-	20 - 100	0,25	-	
			250	7,1	4,9	40 - 120	0,9	-	
			400	14,6	12,4	60 - 140	1,5	-	
1000	140	1,6	-	80 - 240	2,1	-			
	250	7,1	4,9	120 - 280	3,4	1,2			
	400	14,6	12,4	180 - 380	5,3	3,0			
1000	140	1,6	-	20 - 100	0,6	-			
	250	7,1	4,9	40 - 120	1,6	-			
	400	14,6	12,4	60 - 140	2,6	0,4			
1000	140	1,6	-	80 - 240	3,6	1,4			
	250	7,1	4,9	120 - 280	5,6	3,4			
	400	14,6	12,4	180 - 380	8,6	6,4			

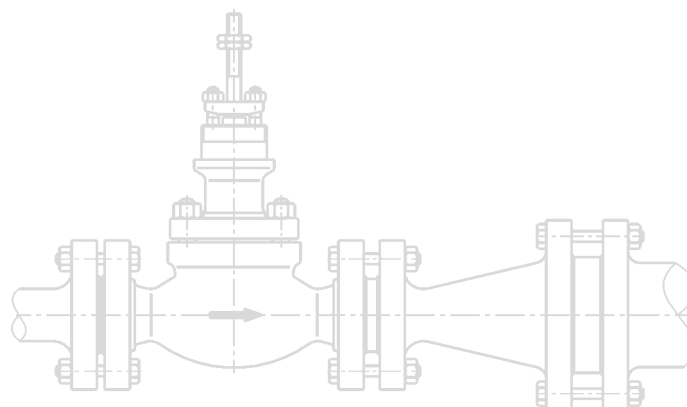

Tab. 6: Continued

Diameter valve seat [mm]	Nominal size valve [DN]	Stroke [mm]	Actuator size	Increase control pressure „close valve“			Increase control pressure „open valve“		
				Sup. pressure [kPa]	ΔP [MPa]		Spring range [bar]	ΔP [MPa]	
					Cl. IV	Cl. V		Cl. IV	Cl. V
66,7	80; 100; 150	38	630	140	0,4	-	20 - 100	-	-
				250	2,4	0,6	40 - 120	0,4	-
				400	5,0	3,3	60 - 140	0,8	-
	80; 100; 150; 200		1000	140	0,8	-	80 - 240	1,1	-
				250	4,0	2,2	120 - 280	1,8	-
				400	8,3	6,5	180 - 380	2,9	1,1
1500	140	1,4	-	20 - 100	0,3	-			
	250	6,1	4,4	40 - 120	0,8	-			
	400	12,5	10,8	60 - 140	1,4	-			
88,9	100; 150; 200; 250	50	1000	140	0,4	-	80 - 240	2,0	0,2
				250	2,2	1,0	120 - 280	3,1	1,4
				400	4,6	3,4	180 - 380	4,8	3,0
			1500	140	0,7	-	20 - 100	0,5	-
				250	3,4	2,1	40 - 120	1,4	-
				400	7,0	5,8	60 - 140	2,3	0,5
107,92	150; 200; 250	63	1000	140	0,3	-	80 - 240	3,1	1,4
				250	1,4	0,4	120 - 280	4,8	3,0
				400	3,0	2,0	180 - 380	7,4	5,6
			1500	140	0,5	-	20 - 100	0,5	-
				250	2,3	1,3	40 - 120	1,4	-
				400	4,7	3,7	60 - 140	2,3	0,5
3000	140	1,1	0,1	80 - 240	3,1	1,4			
	250	4,8	3,7	120 - 280	4,8	3,0			
	400	9,6	8,6	180 - 380	7,4	5,6			
126,95	150; 200; 250	80	1500	140	0,3	-	20 - 100	0,1	-
				250	1,6	0,8	40 - 120	0,4	-
				400	3,4	2,5	60 - 140	0,7	-
			3000	140	0,8	-	80 - 240	1,1	0,1
				250	3,4	2,5	120 - 280	1,7	0,5
				400	7,0	6,1	180 - 380	2,7	1,4

Tab. 6: Continued

Diameter valve seat [mm]	Nominal size valve [DN]	Stroke [mm]	Actuator size	Increase control pressure „close valve“			Increase control pressure „open valve“		
				Sup. pressure [kPa]	ΔP [MPa]		Spring range [kPa]	ΔP [MPa]	
					Cl. IV	Cl. V		Cl. IV	Cl. V
158,72	200; 250	100	1500	140	0,2	-	20 - 100	-	-
				250	1,0	0,3	40 - 120	0,2	-
				400	2,1	1,4	60 - 140	0,3	-
			3000	140	0,5	-	80 - 240	0,5	-
				250	2,1	1,4	120 - 280	0,8	0,1
				400	4,4	3,7	180 - 380	1,2	0,6
203,2	250	100	1500	140	-	-	20 - 100	-	-
				250	0,6	-	40 - 120	-	-
				400	1,3	0,7	60 - 140	0,2	-
			3000	140	0,3	-	80 - 240	0,3	-
				250	1,3	0,7	120 - 280	0,45	-
				400	2,7	2,1	180 - 380	0,7	0,2

**Note**

1. Valves operating „control pressure increase - the valve opens“, an actuator with the spring range of 40-120 kPa can be replaced with an actuator with 40-200 MPa spring range, with the same pressure drops.
2. For reversed operation actuators (R or R1 type), the supply pressure shall exceed the spring higher range by 40 kPa minimum.

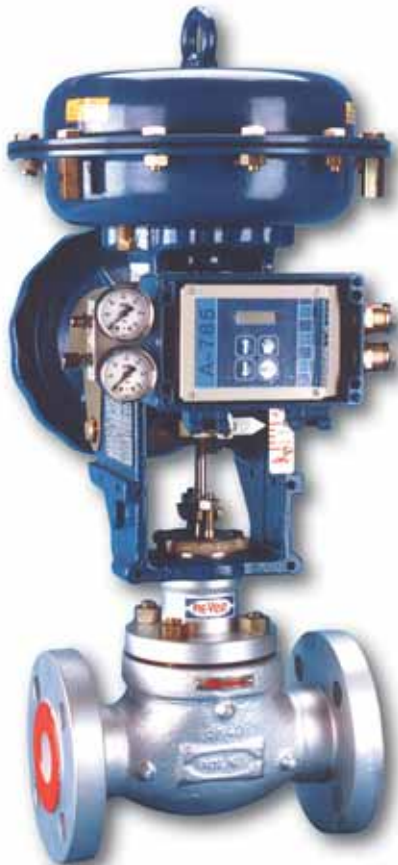

**Globe-cage control valve type 12b**

The valve for challenging and critical applications.



# Noise reduction

The noise generated out of valve operation caused by cavitations or by aerodynamic effects exceeds the level acceptable by the client, it shall be reduced by means of the following solutions.

1. Internal reducing cages (figs. 1a and 1b)
2. Silencer plates on the valve outlet (fig. 3)
3. Reduction joints (diffusers) (fig. 4)

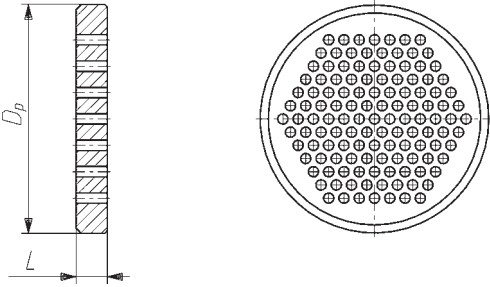

**Fig. 3**  
Silencer plate

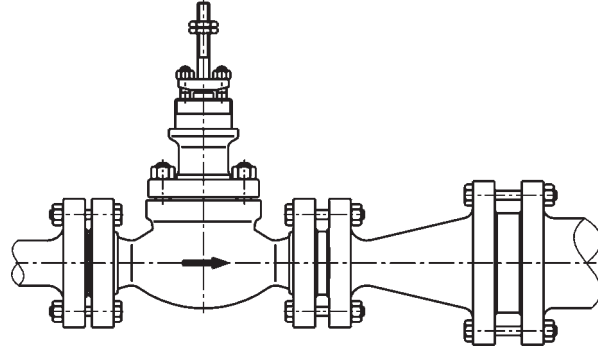

**Fig. 4**  
Installation of silencer plates or a diffuser

**Tabelle 7: Dimensions and flow coefficients of silencer plates**

DN	25	40	50	80	100	150	200	250	300	350
Kvs	10	25	40	94	160	320	500	800	1000	1500
	9	22,5	36	84	144	288	450	720	900	1350
	8	20	32	75	128	256	400	640	800	1200
	7	17,5	28	66	112	224	350	560	700	1050
L [mm]	5	6	10	15	20					
Dp [mm]	68	88	102	138	162	218	285	345	410	465

Multi-plate silencer sets are designed to the individual process requirements.

## Dimensions and weight

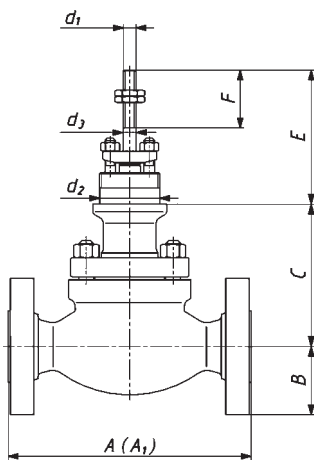

Valve with flanged connection  
Dimension E for the valve position  
valve closed \*E = 180 mm  
while assembled with P/R 1000

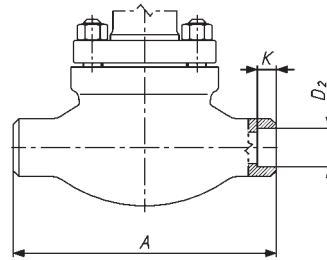

Valve with welding ends SW type (DN 15 ... 50)

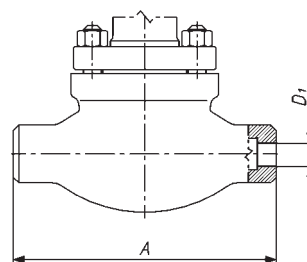

Valve with welding ends BW type (DN 15 ... 50)

**Tab. 8: Connection dimensions of control valve**

DN	25						40						50					
PN	10 ... 50	63 ... 110	150; 160	250; 260	320	400; 420	10 ... 50	63 ... 110	150; 160	250; 260	320	400; 420	10 ... 50	63 ... 110	150; 160	250; 260	320	400; 420
B max	63	70	75		80	90	78	85	93		98	110	83	98	108		105	118
C	ST*	135		149	193		145		172	214			155		175	237		
	V	306		320	364		306		348	385			326		345	402		
	FB	254	-	-	-	-	-	254	-	-	-	-	-	270	-	-	-	-
Weight [kg]	8	8,5		9,5		15,5		17,5	19	20	22	23	22	25	28	31	33	34

DN	80						100						150		
PN	10 ... 50	63 ... 110	150; 160	250; 260	320	400; 420	10 ... 50	63 ... 110	150; 160	250; 260	320	400; 420	10 ... 50	63 ... 110	150; 160
B max	105	115	120	133	138	153	128	138	145	155	168	185	160	178	190
C	ST*	206		233	257		217		252	329			287		365
	V	375		402	447		407		442	498			426		483
	FB	405	-	-	-	-	-	405	-	-	-	-	-	470	-
Weight [kg]	40	43	44	50	51	52	65	72	75	86	89	95	132	147	156

DN	200			250			
PN	10 ... 50		63 ... 110	10 ... 50		10 ... 50 (kv 800)	63 ... 110
B max	190		215	225		255	
C	ST*			439			458
	V			539			558
	FB		580	-	580	660	-
Weight [kg]	195		220	320		330	360

**Note**  
Weight of the control valve with standard bonnet, no actuator

\* ST = Standard bonnet  
V = Extended construction  
FB = Bellows seals

**Tab. 8b: Connection dimensions of control valve**

DN	40 ... 50	50	80	80; 100	80; 100	100	150			200	200; 250		250			
Kvs <sup>1)</sup>	10 ... 25	40	25	40	63; 94	125; 160	63; 94	125; 160	200; 250	320	94	125; 160	200; 250	320	500	630; 800
Hub	20	38	20	38	38	50	38	50	63	80	38	50	63	80	100	
d <sub>1</sub>	M12 x 1,25			M16 x 1,5			M20 x 1,5			M16 x 1,5	M20 x 1,5		M24 x 1,5			
d <sub>2</sub> <sup>1)</sup>	57,15 / 2 1/4"-16UN2A						84,15 / 3 5/16"-18NS2A			95,25 / 3 3/4"-12UN2A						
d <sub>3</sub>	12		16			20			24							
Actuator	250	630	250	630	630	1000	630	1000	1000	1500	1000 1500	1000	1500	1500 3000	1500 3000	
	400		400	1000		1000	1500	1000	1500							
	630		630	1500		1500	3000	3000	3000							

1) For DN 80 an 100 valves with TA-Luft packing, dimension d<sub>2</sub> = 84,15

**Tab. 9: Construction lengths of control valves with flanged connection**

DN	Dimension A [mm]										
	PN; DN; ISO					ANSI (RF) lbs					
	10; 16; 25; 40	63 - 100	160	250 - 320	400	150	300	600	900	1500	2500
25	160	230	230	260	300	184	197	210	248	273	308
40	200	260	260	300	350	222	235	251	270	311	359
50	230	300	300	350	400	254	267	286	311	340	400
80	310	380	380	450	500	298	317	336	387	460	498
100	350	430	430	520	580	353	368	394	464	530	575
150	480	550	550	-	-	451	473	508	556	-	-
200	600	650	-	-	-	543	568	610	-	-	-
250	730	775	-	-	-	673	708	752	-	-	-

**Tab. 10: Construction lengths of control valves with welding ends**

DN	Dimension A [mm]		
	Pressure rating		
	PN 10 ... 110	PN 150 ... 160	PN 250 ... 420
25	210	230	300
40	251	260	350
50	286	300	400
80	337	380	500
100	394	430	580
150	508	550	-
200	610	-	-
250	752	-	-

**Tab. 11: Butt welding ends type BW PN 10 ... 110**

DN	Pipe		Pressure rating			Valve end connection	
	D <sub>z</sub> [mm]	t [mm]	PN ≤ 40	PN 63	PN 100	D <sub>1</sub> [mm]	Norm
25	33,7	2,6	x	x	x	25,2	DIN 3239
40	48,3	2,6	x	x	x	48,8	
50	60,3	3,2	x	x	x	53,6	
80	88,9	4,0	x	x	x	80,6	
100	114,3	5,0	x	x		104	
150	168,3	5,6	x	x	x	156,8	
		7,1			x	153,8	
200	219,1	7,1	x	x		204,6	
		10,0			x	198,8	
250	273	8,0	x			256,7	
		8,8		x		255	
		12,5			x	247,7	

DN	Pipe			Pressure rating			Valve end connection	
	Schedule	D <sub>z</sub> [mm]	t [mm]	PN 20	PN 50	PN 110	D <sub>1</sub> [mm]	Norm
25	40	33,7	3,37	x	x	x	26,7	ANSI B16-25
40		48,3	3,68	x	x	x	40,7	
50		60,3	3,91	x	x	x	52,2	
80		88,9	5,48	x	x	x	77,7	
100		114,3	6,02	x	x	x	102	
150		168,3	7,1	x	x	x	153,8	
200	30	219,1	7,03	x	x		204,7	
	40		8,18		x		202,5	
	60		10,3			x	198	
250	30	273	7,79	x	x		257	
	40		9,27		x		254	
	60		12,7			x	247,2	

**Tab.12: Butt welding ends BW type BW PN 150 ... 240**

DN	Pipe		Pressure rating				Valve end connection	
	D <sub>2</sub> [mm]	t [mm]	PN 160	PN 250	PN 320	PN 400	D <sub>1</sub> [mm]	Norm
25	33,7	3,2	x				27	DIN 3239
		3,6		x			26,2	
		5,0			x		23,5	
	42,4	7,1				x	19,5	
40	48,3	3,8	x				40,5	
		5,0		x			38	
		6,3			x		35,5	
	60,30	11,0				x	38	
50	60,3	4,0	x				52	
		8,0		x			44	
	76,1	8,8			x		58,3	
		14,2				x	47,5	
80	88,9	6,3	x				76	
		11,0		x			92	
	114,3	14,2			x		85,7	
		17,5				x	79	
100	114,3	8,0	x				98	
	139,7	12,5		x			114,5	
		16,0			x		107,5	
		20,0				x	99,5	
150	168,3	12,5	x				143	

DN	Pipe			Pressure rating			Valve end connection	
	Schedule	D <sub>2</sub> [mm]	t [mm]	PN 150	PN 250	PN 420	D <sub>1</sub> [mm]	Norm
25	80	337	4,54	x	x		24,4	ANSI B16-25
	160		6,35		x	x	20,7	
	XXS		9,1			x	15,2	
40	80	48,3	5,08	x			38	
	160		7,13		x	x	33,7	
	XXS		10,16			x	27,7	
50	80	60,3	5,53	x			49	
	160		8,73		x		42,5	
	XXS		11,07			x	38	
80	80	88,9	7,62	x			73,4	
	160		11,12		x	x	66,5	
	XXS		15,24			x	58,2	
100	80	114,3	8,55	x			97	
	120		11,12		x		91,7	
	160		13,48			x	87	
	XXS		17,11			x	79,8	
150	80	168,3	10,9	x			146,2	
	120		14,27	x			139,5	

**Info:**

D<sub>2</sub> [mm] - Pipe outside diameter

C [mm] - Pipe wall thickness

**Tab.13: socked welding ends SW type**

Type	D <sub>2</sub>	K
25	34	13
40	48,7	
50	61	16

# Valve drive

**Pneumatic:** Pneumatic multispring diaphragm actuator (Tab. 14)

**Variants**

- P1/R2 - With cast yoke, no manual drive
- P1B/R1B - With cast yoke, lateral manual drive
- P/R - Column, no manual drive
- PN/RN - Column, top manual drive

**Info:** P - Straight operation; by control pressure increase the valve is closed  
 R - Reverse operation; by control pressure increase the valve is opened

**Tab. 14: Types of pneumatic actuators**

Type	Actuator size	Diaphr. act. area (cm <sup>2</sup> )	Stroke [mm]	Number of turns for full stroke
P/R ; PN/RN	250	250	20	5
	400	400		
P1/R1 ; P/R; P1B/R1B ; PN/RN	630	630	20; 38	5; 9
	1000	1000	38; 50; 63	8; 10; 13
P1/R1 ; P1B/R1B	1500	1500	38; 50; 63; 80; 100	8; 10; 13; 16
	3000	2 x 1500		

**Tab. 15: dimensions and weight of pneumatic actuators P/R and PN/RN - fig. 6**

Actuator size	D <sub>1</sub>	D <sub>2</sub>	H <sub>1</sub>	H <sub>2</sub>	Weight [kg]	
	[mm]				P/R	PN/RN
250	240	225	377	474	10	14,5
400	305		387	484	16	20,5
630	375	305	477	574	30	37
1000	477	450	638	815	74	100

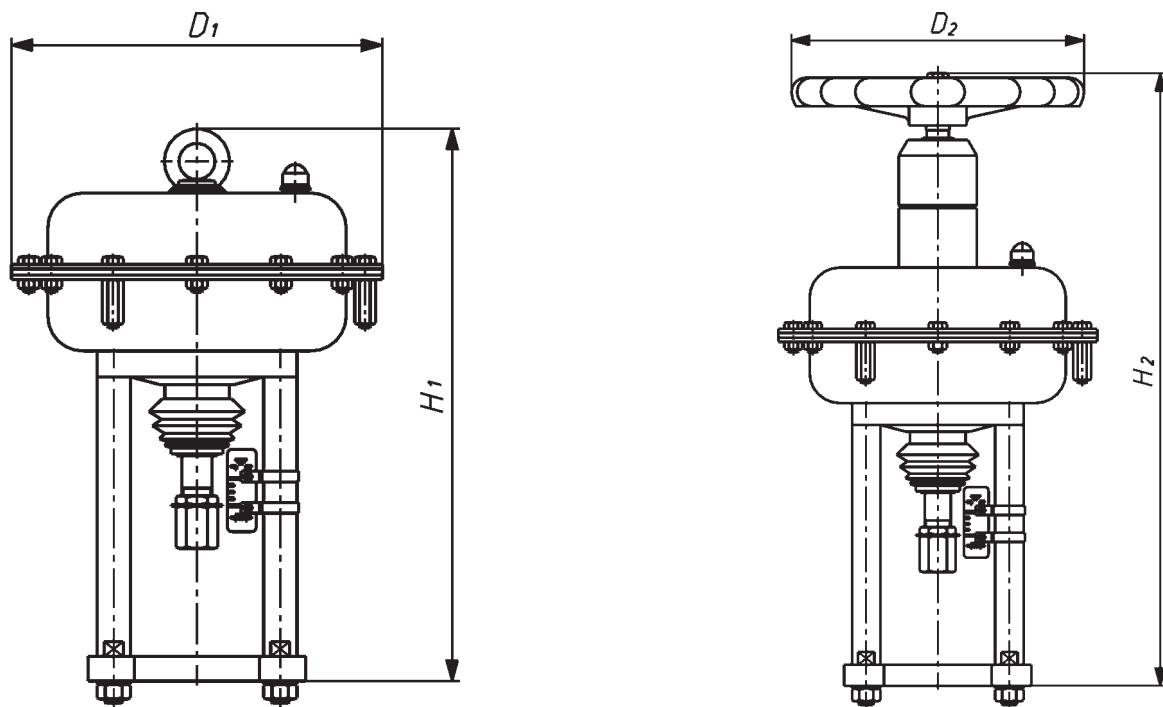

**Fig. 6: Pneumatic Actuators type P/R, PN/RN**

**Tab. 16: Dimensions and weight of pneumatic actuators P1/R 1und P1B/R1B - Fig. 7**

Actuator size	B	D1	D2	H	Weight [kg]	
	mm				P1/R1	P1B/R1B
400	255	305	225	453	20	28
630	280	375	305	548	40	50
1000	340	480	450	773	85	105
1500	410	550		833	120	150
3000				1138	225	255

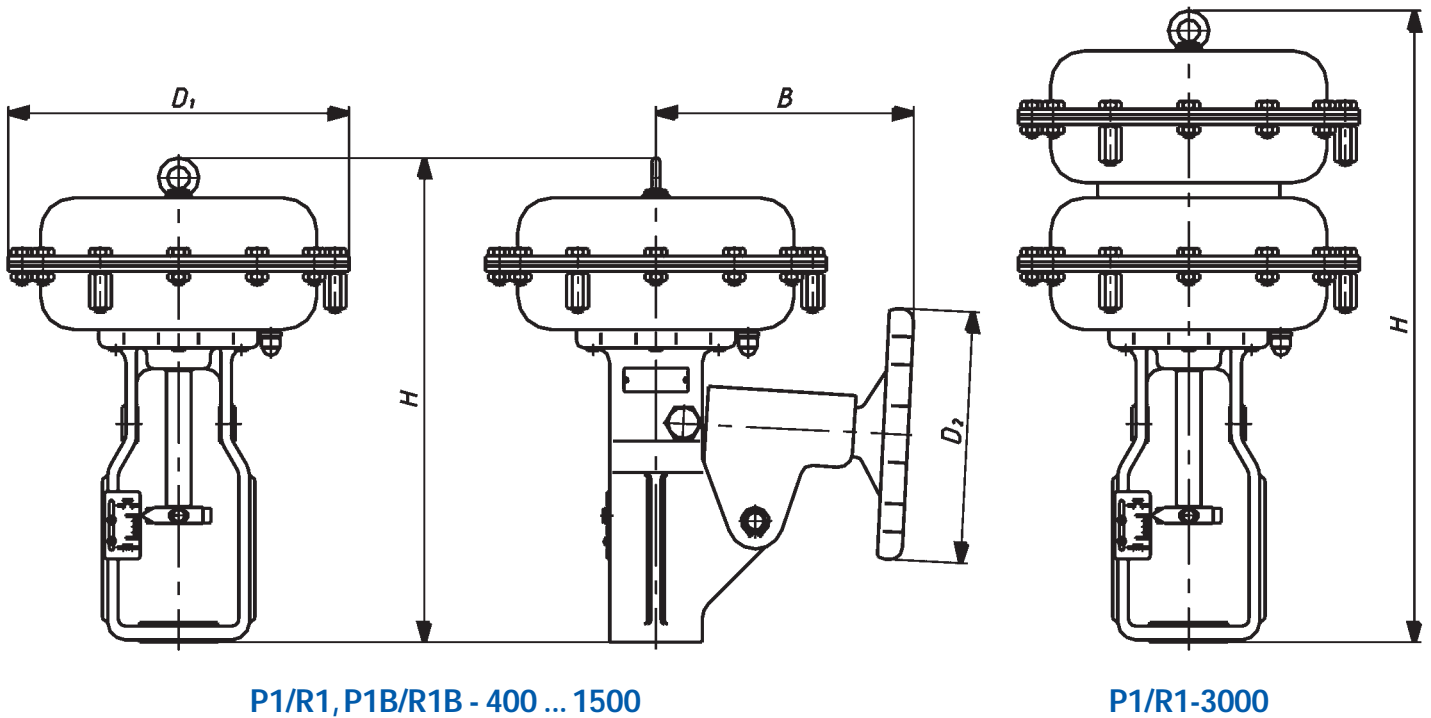

**Fig. 7: Pneumatic actuators type P1/R1 ,P1B/R1B**

**Control air connections**

¼" NPT; Rc ½"

**Spring ranges**

20 ... 100 kPa; 40 ... 120 kPa; 60 ... 140 kPa = 3 springs  
 40 ... 200 kPa; 80 ... 240 kPa; 120 ... 180 kPa = 6 springs  
 180 ... 380 kPa = 12 springs

For P1/R1-3000 actuator (tandem) – for each range, the number of springs is twice than above

**Maximum supply pressure**

450 kPa

**Equipment (optional)**

- Manual drive, lateral (P1/R1), or top (P/R)
- Air operated valve positioner
- Electro pneumatic positioner
- Intelligent (digital) electro pneumatic positioner
- Filter regulator
- Three-way solenoid valve
- Shut-off-block
- Position indicator
- Limit switches

Designs with electrical and electro hydraulic actuators are possible.

Various electric actuators from different manufacturers with BR 12b valves can be delivered on customer's request.

**Tab. 17: Types, dimensions and weight of manual drive type 20 Fig. 8**

Type	Stroke [mm]	d <sub>1</sub>	d <sub>2</sub>	H	D	Number of turns with full opening	Weight [kg]
20-20-57-M12	20	M12 x 1,25	57,15	265	228	8	7,5
20-38-57-M12	38	M16 x 1,5			298	15	
20-38-57-M16			298				
20-38-84-M16			84,15				
20-38-95-M16	95,25	M16 x 1,5	57,15	385	457	16	16
20-50-57-M16	84,15						
20-50-84-M16	84,15						
20-50-95-M16	95,25	M20 x 1,5	84,15	533	533	20	24
20-63-84-M20	84,15						
20-63-95-M20	95,25						
20-80-84-M20	80	M20 x 1,5	84,15	533	533	19	24
20-80-95-M20							
20-100-95-M24	100	M24 x 1,5	95,25	533	533	19	24

Example: 20-38-57-M12 - Manual drive type 20, Stroke 38 mm; d<sub>2</sub>= 57,15 mm; d<sub>1</sub>= M12 x 1,25

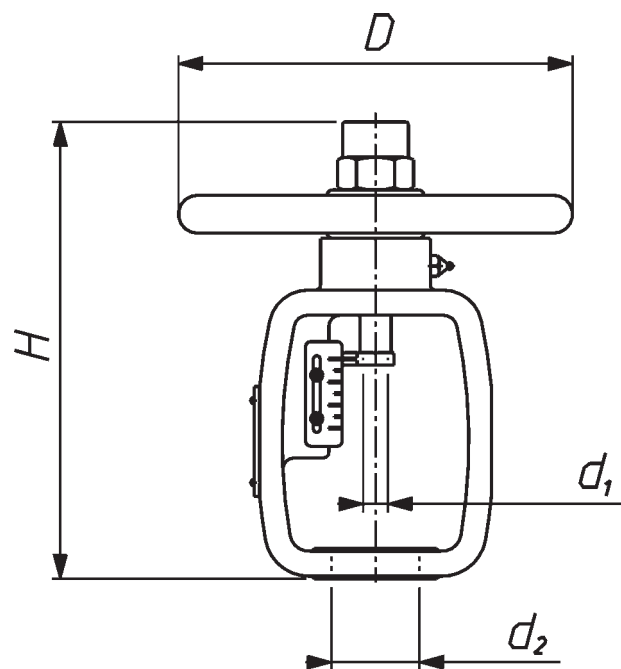

**Fig. 8:**  
Manual drive type 20

**Special versions:**

- **Oxygen valves**  
Proper material selection, mechanical and chemical cleaning, tests and installation guarantees the valve to be prepared for oxygen service
- **Valves for liquid and gaseous fluids**  
Driven by pneumatic actuators with quick closing systems - valve closing time-below 1 sec.
- **Valves for cryogenic service**  
Proper materials and special designs of the seal to prevent the valve drive from being affected by low temperatures. Used for liquid oxygen and nitrogen mainly until -198° C
- **Acid resistant valves**  
Use of special materials for increased acid resistance, according to NACE MR - 1075 Standard
- **Valves with a heating jacket**  
Design and technical parameters as agreed with the client individually
- **Gas density design**  
When class VI of the valve seat leakage is needed (to  $\Delta P \leq 3,5$  MPa)



**Special-purpose solutions  
a problem?**

**Not with PRE-VENT®-valves!**

**Ask our specialists!**

**EMSR-Tech**

**Vertriebs- Logistik- und Produktions GmbH**

Gewerbepark Lindach A9  
D-84489 Burghausen

Phone +49 86 77 987 880

Fax +49 86 77 987 8880

E-Mail: [office@emsr-tech.com](mailto:office@emsr-tech.com)

[www.pre-vent.com](http://www.pre-vent.com)

*Local distributor:*



**strong**  
**arguments**  
of modern technology